

evo_2/e™
contemporary landscape

INSTALLATION MANUAL



ENGLISH

MIRAGE®
Ceramics . Design . Sustainability

Dear Customer,

Thank you for choosing **Evo_2/E™**, the first porcelain stoneware to have a thickness of 20mm, produced and marketed by **Mirage®** as a complete project for outdoors and gardening.

A complete system of floorings and special pieces for public and residential outdoor spaces that provides a wide range of sizes, colors and finishes and different modes of application.

This manual was conceived from the desire to provide our customers valuable tips for laying the material; a simple and exhaustive tool, in order to obtain the best result in terms of appearance and quality.

The information contained in this guide is the result of the experience acquired from **Mirage®** and the daily interaction with professionals of the sector.

Mirage® nevertheless invites you to comply with the local laws and regulations of each individual country to produce flooring in accordance with the best working standards. We also recommend you carefully assess the characteristics of the substructure before doing any type of machining or installing.

Note: For North America and Oceania markets please refer to the specific manual.



- 2 PORCELAIN STONWARE MIRAGE®
- 4 THE ADVANTAGES OF PORCELAIN STONWARE
- 7 VERIFICATION OF THE SUB-BED
- 8 LAYING SYSTEMS
 - 8 LAYING IN SUPPORT WITH GRASS
 - 10 LAYING ON SCREED WITH GLUE
 - 12 RAISED LAYING
 - 22 LAYING ON SAND
 - 24 LAYING ON GRAVEL
 - 28 LAYING ON GRAVEL MIXED WITH CONCRETE
 - 32 JOINTS
 - 33 COMPACTIONS

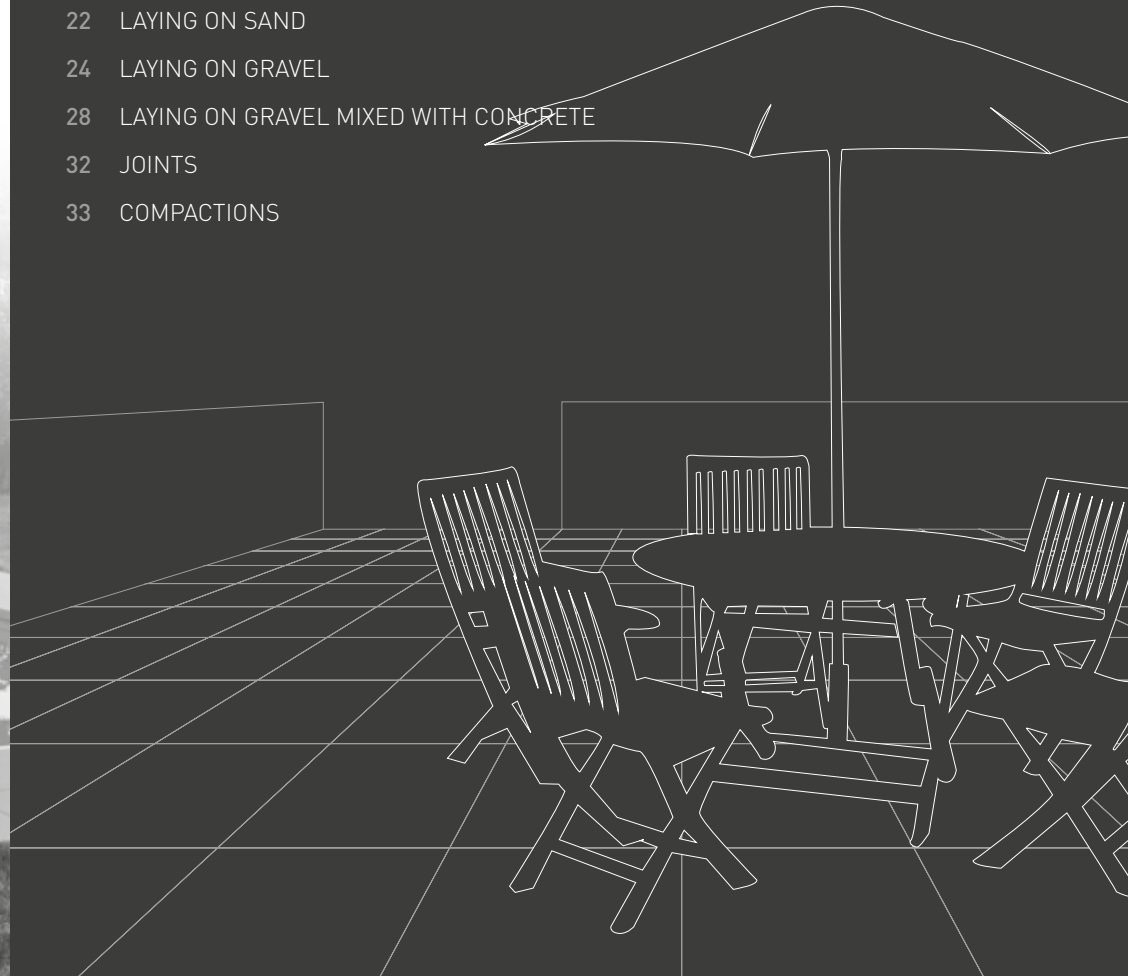

It is a material with high technical and visual performance. Slabs obtained by pressing, followed by a process of vitrification: i.e. the complete melting into a single material of natural raw materials (sand, quartz, feldspar, kaolin, clays, and natural dyes) that, cooked at temperatures in excess of 1230°C, arrive to constitute **a product of exceptional hardness, having almost nil absorption and unequalled mechanical characteristics.** Mirage® porcelain stoneware is an eco-compatible and Ecolabel-certified product.



Resistant



TO THERMAL SHOCK

Because it is 100% frost-free and its properties remain unaltered at temperatures of -50°C to +60°C (-120°F to +140°F).



to loads

Because every slab can withstand loads of over 1000 kg (2200 lb).



to chemical aggression

Because it totally resists acids, chemical agents, salt and verdigris.



to stains

Because it remains unaltered over time, mould and moss and dark smudges cannot get a hold.

Easier



to clean

Because it requires no special or seasonal treatment and can be washed easily, even using a pressure washer.



to lay

Because it is a squared, single work-size, which uses the same laying systems as other common outdoor materials.

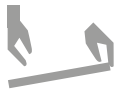

to remove

Because it is removable, serviceable and reusable, weighing just 17 kg per 60x60 cm slabs (37 lb per 24"x24" slabs) (excluding laying on screed with glue).



for you

Because it is non-slip thanks to the structured surface.

Respectful of the environment



Ecolabel

EVO_2/E™ collections guarantee low environmental impact throughout their life cycle, in compliance with the strictest European ecological and technical parameters.



Leed Compliant

All the slabs in the Mirage® catalogue are LEED compliant and help to obtain up to 10 LEED credits, depending on colour and use.



Made in Italy

All Mirage® tiles are designed and produced entirely in Italy, an element which today more than ever bears witness to the company's desire to promote the quality and values of Italian-made goods.



HY-PRO²⁴

The Mirage® treatment, available on request, with titanium dioxide, enhanced with active metal elements, makes the material photocatalytic, anti-pollutant, hygienic and anti-bacterial, 24 hours a day.

Contemporary Landscape



attention to detail

Because it has a range of highly attractive solutions, with special pieces for different uses and to create innovative surfaces.



wide range

Because you can choose from a range of over 40 interpretations of stone, wood and concrete.



total coordination

Because you can create fully coordinated interiors and exteriors, in different colours.









versatility

Because you can use a range of laying systems for many specific solutions, in gardens, parks, terraces, courtyards and swimming pools.

LAYING GUIDE

The project **EVO_2/E™ Mirage®** brings you a set of solutions for installation suitable for all soils and outdoor surfaces, to guarantee the **maximum application versatility**.

There are many uses, for private external and public spaces:

| | |
|---|----------------------------|
|  | Garden, courtyard or patio |
|  | Footpath |
|  | Terrace or balcony |
|  | Swimming Pool |
|  | Driveway flooring |
|  | Commercial Area |

Depending on the applications, the following table gives recommendations of some installations to ensure maximum effectiveness.

| | ON GRASS | DRY INSTALLATION ON SAND | DRY INSTALLATION ON GRAVEL | ON GRAVEL MIXED CEMENT | RAISED | ON SCREED |
|-----------------|----------|--------------------------|----------------------------|------------------------|--------|-----------|
| GARDEN | • | • | • | • | • | • |
| YARD | • | • | • | • | • | • |
| FOOTPATH | • | • | • | • | • | • |
| TERRACE | | • | • | • | • | • |
| SWIMMING POOL | | | | • | • | • |
| DRIVEWAY | | | | | | • |
| COMMERCIAL AREA | | | | | | • |

* The garden, yard, patio, footpath, terrace and swimming pool do not bear vehicular load, but only pedestrian and bicycle load.

** The driveway and the commercial area provide only light vehicular load (← 8500 kg).
Roads and squares are not included in this application. Please contact the Engineering Office at Mirage® for further information.

LAYING GUIDE



When the application of slabs in 20 mm requires the use of the ceramic product in structural terms, it is recommended that the designer and/or client make a careful assessment of the project requirements in relation to the technical characteristics of the slabs.

In particular, in order to avoid the risk of damage to persons or things, the manufacturer recommends that:

- If the application provides for raised laying, taking into account that a tile may break due to a heavy object falling on it, check in advance the specific intended use and follow the "raised installation instructions" table below where, under certain conditions, the application of a reinforcement on the back of the tile is required (rete plus or galvanized steel) supplied by the manufacturer.
- With reference to the flooring laid in altitude, with any dry-laid system, observe the specific rules and regulations and local use conditions regarding, inter alia, by way of example, the action of the wind, the structural load, seismic actions, etc.
- Failure to comply with the recommendations above may lead to an improper use of the product and possibly cause serious damage/injuries to persons or things.

VERIFICATION OF THE SUB-BED

The evaluation of the quality and of the carrying capacity of the floor is not the task only of the layer and then, before entrusting the task of laying, it is fundamental for the clients/designer to ensure compliance of the characteristics of the soil and its compaction to the the forecasts of the loads to which the flooring must respond.

It should be remembered that to avoid stagnation of water and a possible early deterioration of the area, under no circumstances must floorings be made with slopes of less than 1%: the minimum slope recommended is 1.5%.

The information and recommendations listed in this catalogue are for informational purposes only, for the implementation of every step we recommend the application of each rule and the respect of every law concerning the various phases of work.

Mirage® recommends carrying out a careful assessment of the sub-bed characteristics before doing any type of installation.

LAYING IN SUPPORT WITH GRASS



It is the ideal laying solution for creating walkways, barbecue areas and gazebos in the garden: by laying EVO_2/E™ slabs on the ground, you can preserve the underlying lawn, allowing you to enjoy it while preventing it from being damaged by weights or heavy foot traffic.

i HOW TO LAY "JAPANESE STEPPING STONES"

To create a path pattern arranging the slabs in the "Japanese stepping stone" style, you need to calculate the number of steps needed to complete the path, then space the slabs at an equal distance along the route. To ensure perfect stability, it is recommended to dig 5/8 cm, add fine gravel size 3 to 6 mm, and compact the bottom before laying the slab.

The slabs must not protrude above the lawn level, in order not to damage the lawnmower when cutting the grass.

USES



Residential Areas



Garden, courtyard or patio



Footpath



Gazebo

WHAT YOU NEED



Porcelain Stoneware Mirage® Evo_2/E™



Spade



Work Gloves



Gravel Ø 3/6 mm



Square tip trowel



Trowel



Mallet



Mirage® Lifting Tong

LAYING IN PLACE

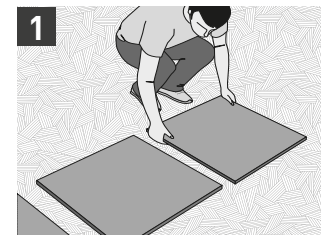
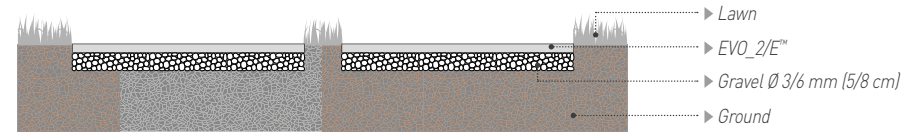

1 Beforehand arrange the Mirage® slabs on the ground to define the correct positioning and distance between the footsteps.

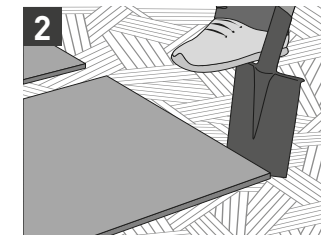

2 Mark the perimeter of the slab by making a few grooves in the ground.

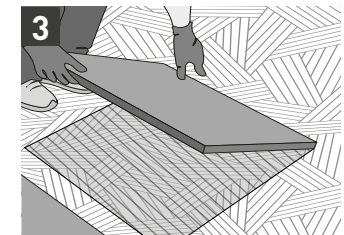

3 Lift the slab and then remove the top layer of grass.

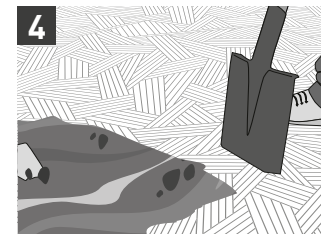

4 Remove the top layer of the turf (to a depth of approx. 6-7 cm).



5 Clean and level the underlying ground.



6 Add a layer of gravel to smooth off the sub-bed and provide more stability.

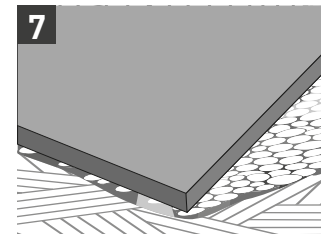

7 Place the slab above the ground level by about 0.5 / 1 cm to allow the subsequent natural levelling to the ground.

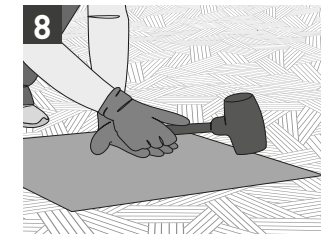

8 Compact the edges to lay the slab flush to the ground.

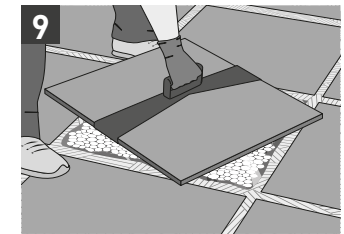

9 In the case where the levelling is not optimal, lift the slab with the appropriate crimping tool and reposition it correctly.

The stratigraphies, shims and the proposed measures are only indicative of the type of application: it is recommended to refer to the specific rules of each individual country or indications of the Layers' Associations, to achieve a flooring job according to the best working standards. Mirage® also recommends carrying out a careful assessment of the sub-bed characteristics before doing any type of machining or laying.

LAYING ON SCREED WITH GLUE

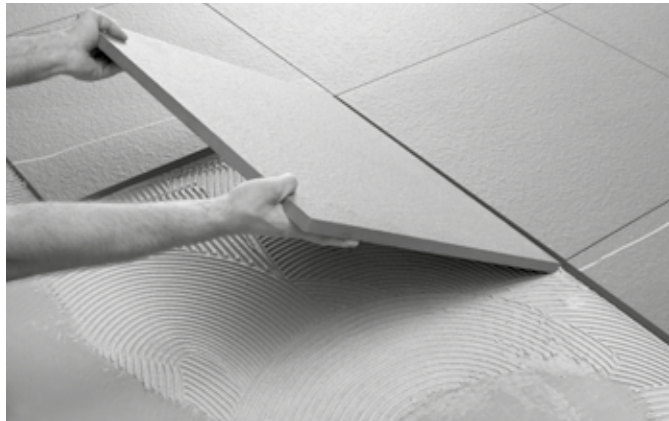

The ideal laying solution for outdoor driveways, car parks, garage ramps, as the laid surface is extremely resistant to both dynamic and concentrated loads. Expansion joints are required and the joints between the tiles must be filled with cement-based grout.

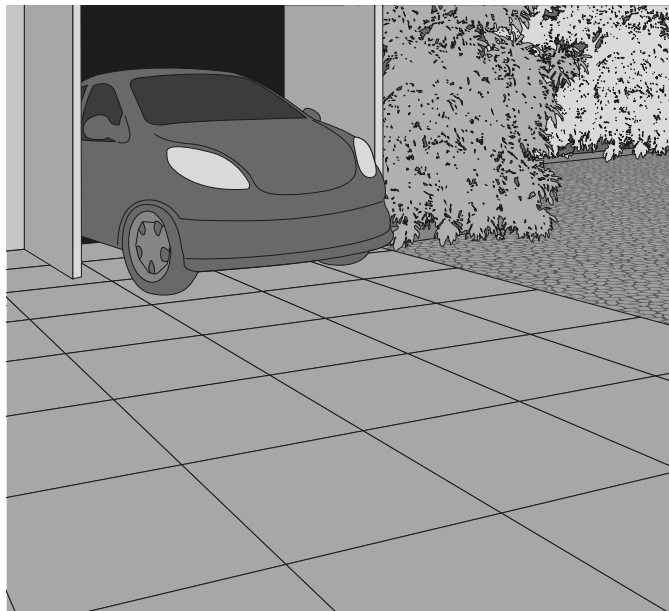

USES

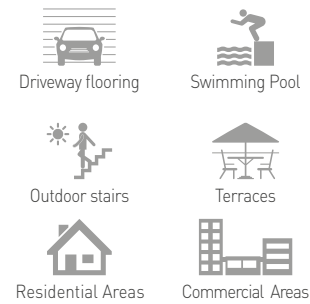

WHAT YOU NEED

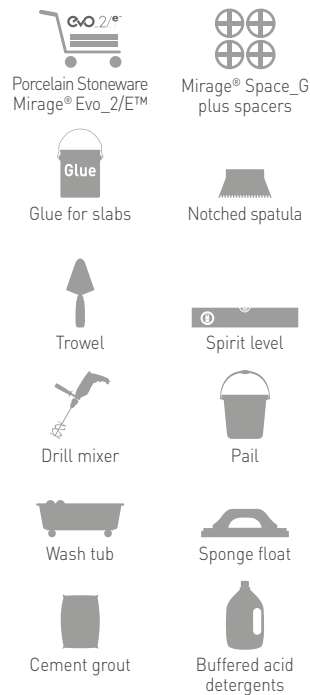

LAYING IN PLACE

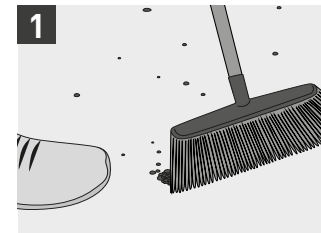
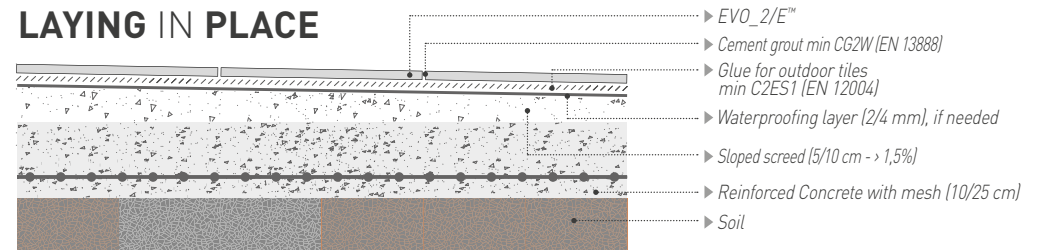

After having made the screed according to the best working standards, it needs a good surface cleaning before proceeding with the laying.

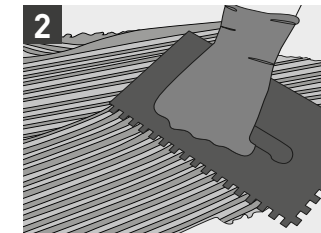

Spread the glue evenly to ensure a perfectly plane surface.

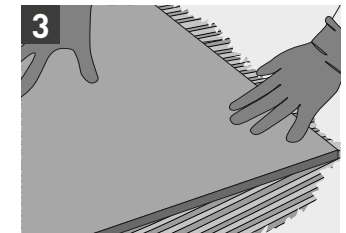

When laying, it is recommended to check that the slab has adhered correctly to the glue layer.

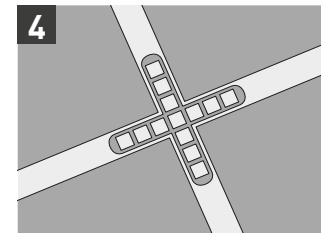

EVO_2/E™ is squared and single work-size and can therefore be laid with a 3 mm plus spacer (plus spacer 3 mm = joint 3/4 mm).

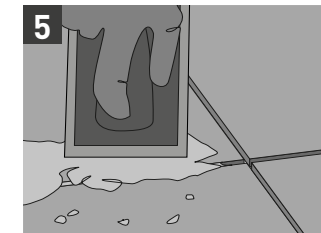

After laying, grout the floor.



Wash the first layer of grout residue carefully after grouting.



A final buffered acid wash must be done to remove any invisible grout residues.

The stratigraphies, shims and the proposed measures are only indicative of the type of application: it is recommended to refer to the specific rules of each individual country or indications of the Layers' Associations, to achieve a flooring job according to the best working standards. Mirage® also recommends carrying out a careful assessment of the sub-bed characteristics before doing any type of machining or laying.

RAISED LAYING



Raised outdoor floors exploits the conventional system of floating or raised floors. With this laying system, all the pipes and wiring systems laid beneath the tiled surface can be inspected at any time. It offers instant accessibility, by allowing the lifting and removal of the slabs.

A slope $\geq 1.5\%$ and a maximum laying height of 10 cm is recommended.



Raised outdoor flooring is used mainly on rather large regular surfaces, or overlapping the previous floor, provided the previous floor shows no signs of infiltration. The open joints between the slabs allow rain water to flow into the cavity that is created under the panels. Thus a planar floor is obtained, while the underlying waterproof layer will have all the slopes required to thoroughly drain off the rain water. The load-bearing structure is made of polypropylene supports with a wide base and rounded edges to prevent damage to the insulating sheath. This solution allows for any underlying elements to be inspected and offers a practical passage for pipes and wiring.

USES



Residential Areas



Commercial Areas



Terraces



Garden, courtyard or patio

WHAT YOU NEED



Porcelain Stoneware Mirage® Evo_2/E™



Support



Adjusting Wrench



Mirage® Lifting Tong



Broom



Dustpan

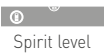

Spirit level

LAYING IN PLACE

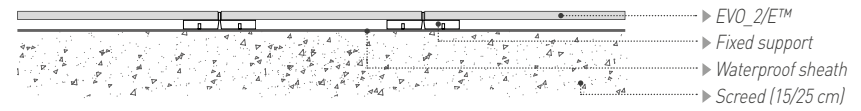

RAISED LAYING (FIXED SUPPORT)

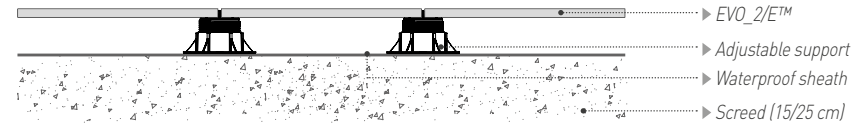

RAISED LAYING (ADJUSTABLE SUPPORT)

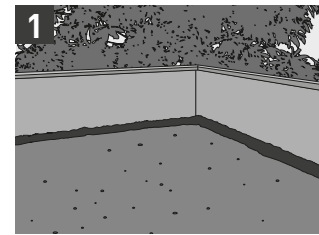

When laying on supports, the sub-bed must be fully waterproofed.



Before laying, clean the sub-bed carefully.

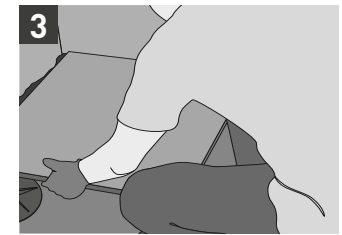

It is advisable to start laying from a corner, if there is one.

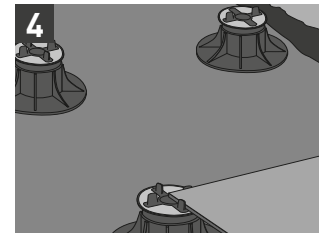

Place the supports in relation to the dimensions of the used slab.

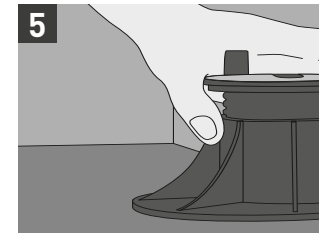

A MAXIMUM LAYING HEIGHT OF 10 CM IS RECOMMENDED.

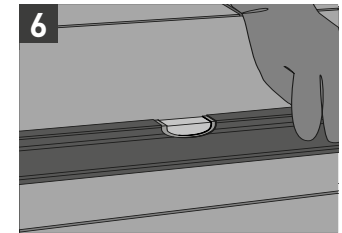

Verify while laying, the proper levelling of the laid slabs ($\geq 1\%$).



To adjust the supports, the appropriate adjustment wrench is available.

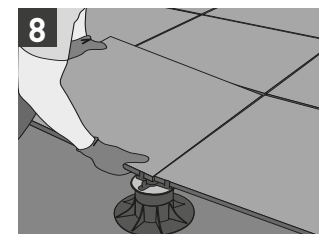



When laying, check that the joint line is always constant.

The stratigraphies, shims and the proposed measures are only indicative of the type of application: it is recommended to refer to the specific rules of each individual country or indications of the Layers' Associations, to achieve a flooring job according to the best working standards. Mirage® also recommends carrying out a careful assessment of the sub-bed characteristics before doing any type of machining or laying.

RAISED LAYING



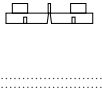

FIXED SUPPORT



| SUPPORT | TYPE | CODE | HEIGHT (mm) |
|---|------|------|-------------|
|  | EH12 | WC50 | 12 |
|  | EH15 | WA12 | 15 |
|  | EH20 | WC51 | 20 |
|  | LH3 | WC52 | 3 |

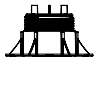

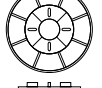
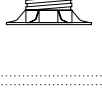



ADJUSTABLE SUPPORT

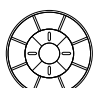
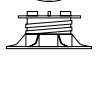

| SUPPORT | TYPE | CODE | HEIGHT (mm) |
|---|------|------|-------------|
|  | NM1 | WC22 | 25-40 |
|  | NM2 | WA13 | 40-70 |
|  | NM3 | WC17 | 60-100 |
|  | NM4 | WC31 | 90-160 |
|  | NM5 | WA86 | 150-270 |
|  | LGH2 | WV37 | 2 |
|  | LGH3 | WF29 | 3 |

SELF-LEVELLING SUPPORT



| SUPPORT | TYPE | CODE | HEIGHT (mm) |
|---|------|------|-------------|
|  | SE0 | WS93 | 28-38 |
|  | SE1 | WC18 | 37,5-50 |
|  | SE2 | WA14 | 50-75 |
|  | SE3 | WC19 | 75-120 |
|  | SE4 | EC20 | 120-170 |
|  | SE5 | EC53 | 170-215 |
|  | SE6 | EC57 | 140-230 |
| | SE7 | EC97 | 185-275 |
| | LGH2 | WV37 | 2 |
| | LGH3 | WF29 | 3 |



When the application of slabs in 20 mm requires the use of the ceramic product in structural terms, it is recommended that the designer and/or client make a careful assessment of the project requirements in relation to the technical characteristics of the slabs.

In particular, in order to avoid the risk of damage to persons or things, the manufacturer recommends that:

- If the application provides for raised laying, taking into account that a tile may break due to a heavy object falling on it, check in advance the specific intended use and follow the "raised installation instructions" table below where, under certain conditions, the application of a reinforcement on the back of the tile is required (rete plus or galvanized steel) supplied by the manufacturer.
- With reference to the flooring laid in altitude, with any dry-laid system, observe the specific rules and regulations and local use conditions regarding, inter alia, by way of example, the action of the wind, the structural load, seismic actions, etc.
- Failure to comply with the recommendations above may lead to an improper use of the product and possibly cause serious damage/injuries to persons or things.

TECHNICAL CHARACTERISTICS OF THE SUPPORTS





SUPPORTS MADE FROM 100% RECYCLABLE MATERIALS

RESISTANT TO ACIDS AND ALKALIS

RESISTANT TO ATMOSPHERIC AGENTS

RESISTANT TO TEMPERATURES FROM -30°C TO +120°C (-90°F TO +250°F)

RAISED LAYING

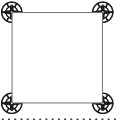
| size | up to 2 cm (3/4") | from 2 cm (3/4") to 10 cm (4") | from 10 cm (4") to 30 cm (12") |
|--|---|--|--|
| 60x60 cm / 24"x24" (rated) 4 supports per slab  | 4 SUPPORTS (3,4 pcs/m ²) | 4 SUPPORTS (3,4 pcs/m ²) | 4 SUPPORTS (3,4 pcs/m ²) + FIBER-MESH PLUS OR GALVANIZED STEEL SHEET |
| 45x90 cm / 18"x36" (rated) 60x120 cm / 24"x48" (rated) 6 supports per slab  | 6 SUPPORTS (6,0 pcs/m ² - 45x90) (3,4 pcs/m ² - 60x120) | 6 SUPPORTS (6,0 pcs/m ² - 45x90) (3,4 pcs/m ² - 60x120) + FIBER-MESH PLUS OR GALVANIZED STEEL SHEET | 6 SUPPORTS (6,0 pcs/m ² - 45x90) (3,4 pcs/m ² - 60x120) + FIBER-MESH PLUS OR GALVANIZED STEEL SHEET |
| 30x120 cm / 12"x48" (rated) 6 supports per slab  | 6 SUPPORTS (7 pcs/m ²) | 6 SUPPORTS (7 pcs/m ²) + FIBER-MESH PLUS OR GALVANIZED STEEL SHEET | 6 SUPPORTS (7 pcs/m ²) + FIBER-MESH PLUS OR GALVANIZED STEEL SHEET |
| 20x120 cm / 8"x48" (rated) 6 supports per slab  | 6 SUPPORTS (11 pcs/m ²) | WITH SPECIAL STRUCTURE SEE E_DECK CATALOGUE | WITH SPECIAL STRUCTURE SEE E_DECK CATALOGUE |
| 90x90 cm / 36"x36" (rated) 4 supports per slab  | 4 SUPPORTS (3 pcs/m ²) | WITH SPECIAL STRUCTURE SEE E_DECK CATALOGUE | WITH SPECIAL STRUCTURE SEE E_DECK CATALOGUE |

i Note: For any detail and technical specification concerning the fiber mesh plus or the galvanized steel sheet, please contact Mirage®. Mirage® is responsible only if it supplies the whole system (tile + fiber mesh plus or galvanized sheet). Mirage® cannot be held responsible for reinforcing systems that has not supplied. In case of breakage, tile must be replaced immediately.

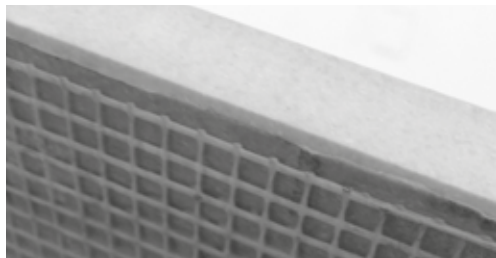

FIBER-MESH PLUS

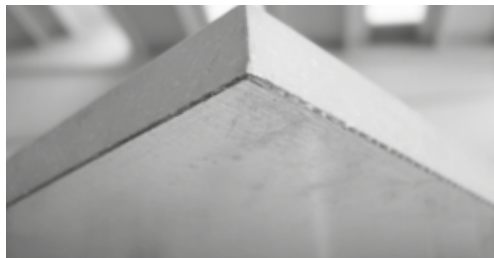

GALVANIZED STEEL SHEET



To ensure drainage of the tread surface, appropriate transversal or longitudinal gradients should be included during levelling and compaction.

Bear in mind, however, that, in the light of the distinctive advantages of porcelain stoneware, EVO_2/E™ has practically nil water absorption, a characteristic that makes it frost-proof. This may lead to localised water pooling, mainly on the edges of the tiles, regardless of the high standard laying. It is also recommended to lay with a minimum joint of 3 mm.

For further information and technical specifications concerning a height of over 30 cm, please contact the Mirage® Engineering Division.

RAISED LAYING

VERTICAL EDGE CLIP

The sure innovation to 'finish off in style'

Designed to solve the common problem of many outdoor flooring systems, i.e. how to close off the edge when there is no perimeter wall. The **vertical edge clip** is an innovative system for closing off the outer edge of raised floors with an easy and elegant solution. The solution consists of two special stainless steel clips that are placed on top and underneath the base, creating a space with edges that grip onto the portion of flooring cut to size for the area to fill, and preventing any horizontal slippage of the slabs at the same time because of the block at the edge of the floor clip.

BOTTOM VERTICAL EDGE CLIP

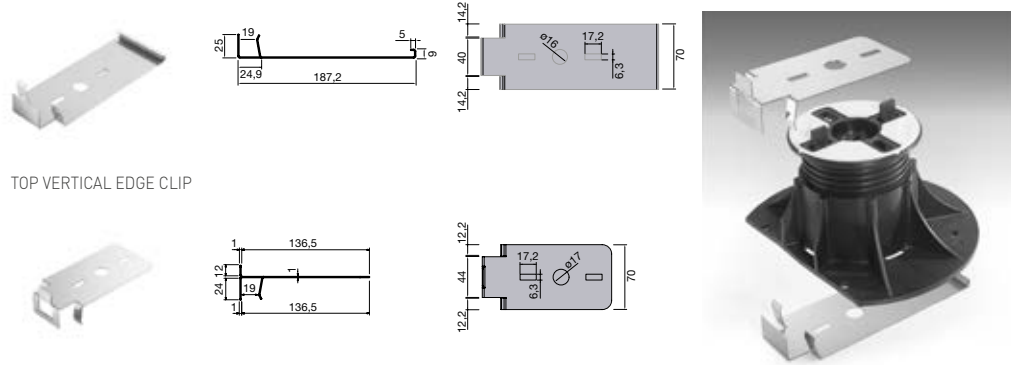

TOP VERTICAL EDGE CLIP

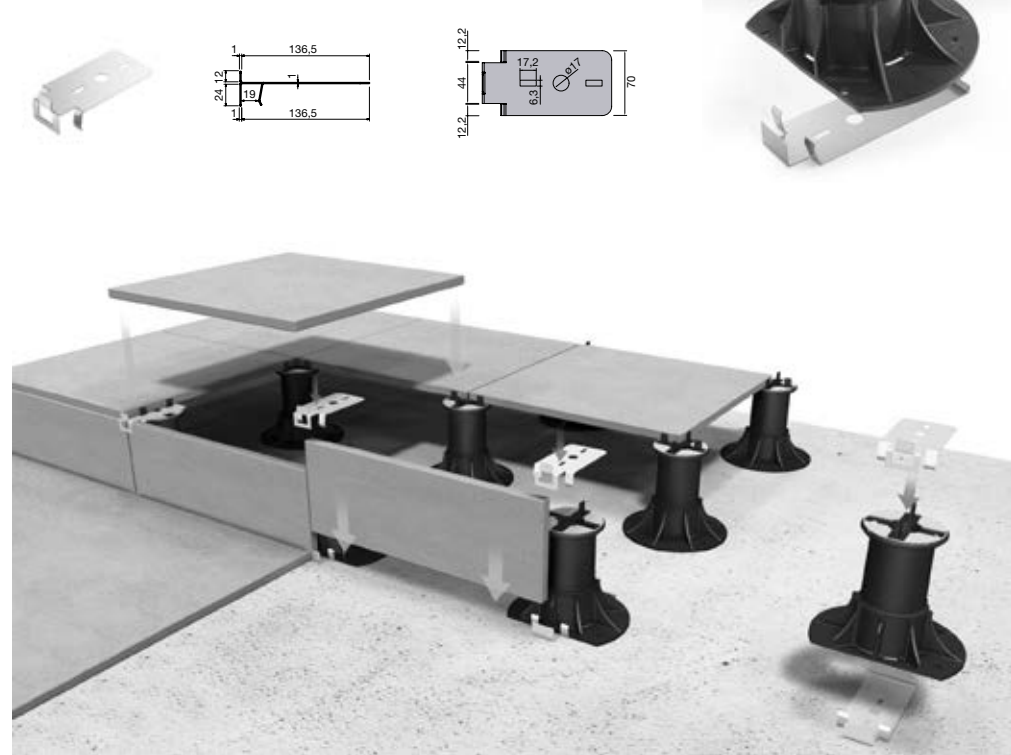

SLAB EDGE CLIP

The ideal combination of looks and functions

Designed to prevent any contact between the slab and the perimeter wall when fitting raised outdoor flooring, the **slab edge clip** is made entirely in stainless steel and has a system to absorb longitudinal and transversal dilation as well as providing a reliable grip, enabling an elegant, straight perimeter gap while giving the floor extra stability.

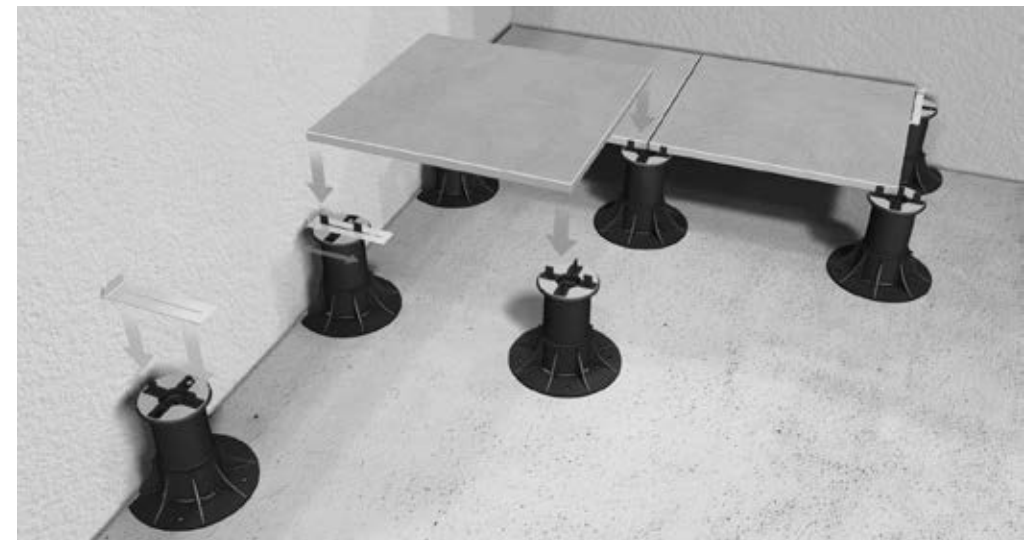
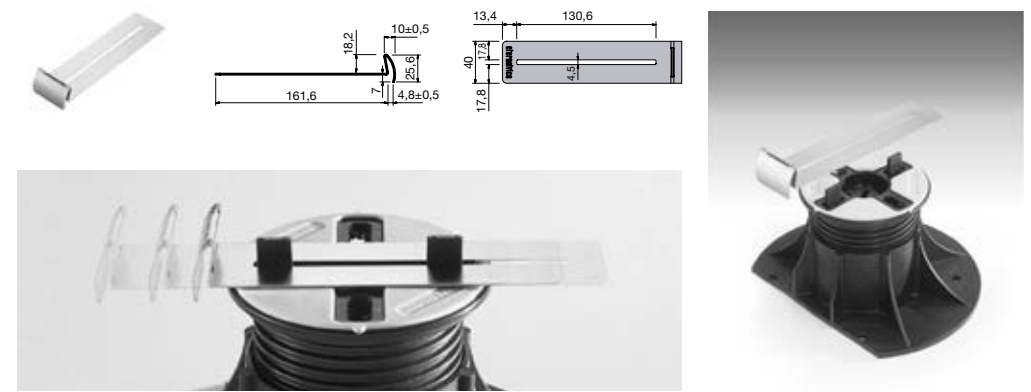

LAYING ON SAND



Dry laying on sand is recommended for applications such as in a garden, patio, courtyard, walkways and terraces. It is a versatile and rapid laying method that allows easy removal of the flooring as a function of the type of joint that is chosen to use.

USES

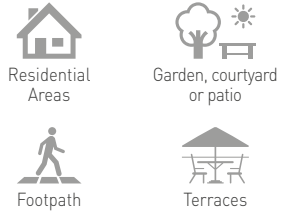

WHAT YOU NEED



LAYING IN PLACE

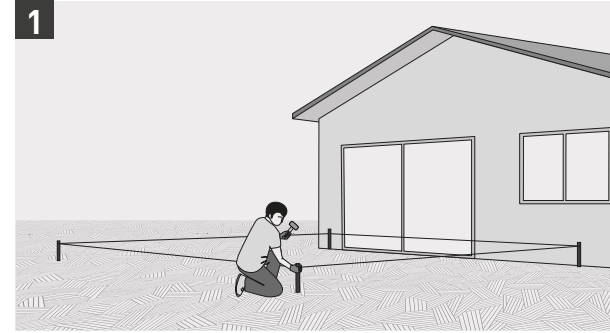
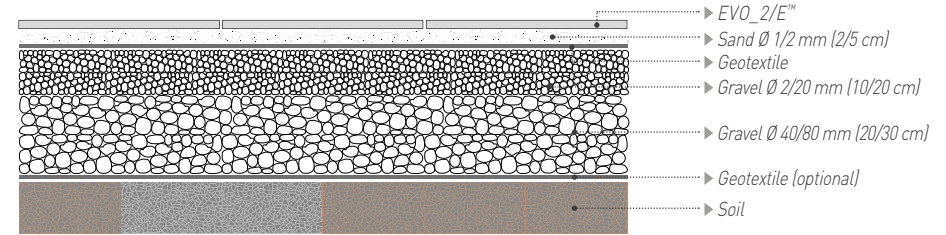

Once you have drawn up the area you need to dig out, you can mark the perimeter of the excavated area using wooden or steel marker posts connected by a string. Allow a lateral strip of land in excess of the marked edge that can be removed during the excavation.

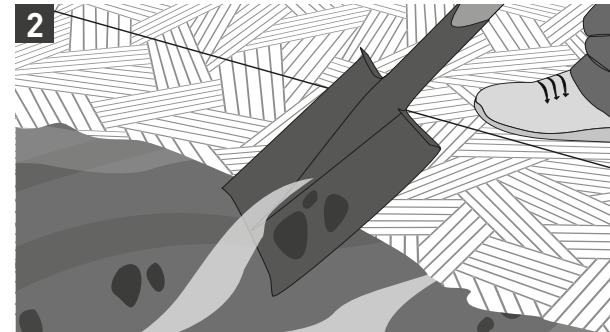

Remove the soil inside the marked area using a shovel or excavator. The depth of excavation should be decided during the planning stage and depends on various factors that the flooring fitter should assess with due care, including:

- the load on the flooring; a larger service load corresponds to a greater thickness of the layers
- the existing conditions of the soil; the undisturbed ground has a greater bearing capacity than the backfill
- drainage capacity of the soil; a greater ability to drain water corresponds to a greater bearing capacity of the ground



NOTE: It is recommended to consult a technician to precisely calculate the thickness of the layers according to the intended use and stressing load.

The stratigraphies, shims and the proposed measures are only indicative of the type of application: it is recommended to refer to the specific rules of each individual country or indications of the Layers' Associations, to achieve a flooring job according to the best working standards. Mirage® also recommends carrying out a careful assessment of the sub-bed characteristics before doing any type of machining or laying.

LAYING ON SAND



Once the excavation is completed, use a rake or shovel to level the excavated area making sure there is at least 2% slope (to facilitate water drainage). Before proceeding with the implementation of the upper layers, compact the soil with a vibro compaction machine.



It is advisable to lay a sheet of geotextile on top of the compacted soil: this is a layer of synthetic material whose main purpose is to prevent the soil from mixing with the gravel and increasing the lifetime of the flooring.



Arrange a layer of gravel with a grain size 40/80 mm, a thickness of between 20 cm and 30 cm, depending on the planned type of load. The main purpose of this layer is to withstand the load on the flooring and serves as the load-bearing element.



Using the same method as for the foundation layer, lay gravel with a size of 0/20 mm, a thickness between 10 and 20 cm, according to the expected load. This layer also has to be compacted and levelled with a gradient of approximately 2%.

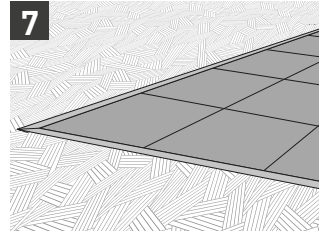

The edging stones or curb stones have the basic purpose to prevent any horizontal movements of the flooring by eliminating any instability of the paved plane. A curb must be fitted along the entire perimeter of the flooring, unless it is in direct contact with a footpath, wall or an existing edge that is sufficiently rigid. It is recommended to install the containing edges in the stage prior to laying the sand bed on which to lay the flooring.

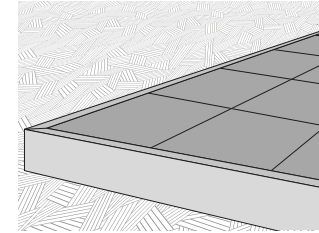

The containing edge must be fixed to the ground with a casting of concrete at the base or by mechanical anchors according to manufacturer-specific indications and according to the material of which they are made. If possible, at least half the height of the curb should be covered with soil on the external side of the flooring.

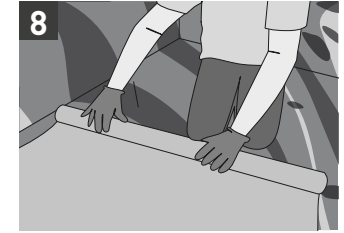

It is advisable to lay a sheet of geotextile on top of the compacted soil: this is a layer of synthetic material whose main purpose is to prevent the soil from mixing with the gravel and increasing the lifetime of the flooring.



The sandy material recommended for the laying of EVO_2/ E™ is the sand with particle size 0-2 mm dry. Make sure the thickness of the layer of sand is between 2 and 5 cm and perform compaction with a vibro compactor plate.



When the layer of sand is sufficiently dense, level the surface by sliding a wooden or steel board appropriately placed on two runners. Finally, use a spirit level to check the gradient of the surface: the optimum gradient is around 2%.

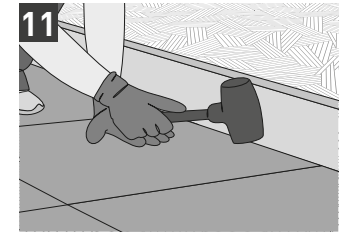

Taking care not to damage the planar surface of the sand bed, start laying EVO_2/E™ using Mirage® Space_G type plus spaces (joint 4 mm). Use a rubber mallet to stabilise the flooring tiles on the bed of sand by delicately tapping their surface.

12

GROUTING: see information on page. 32.

i NOTE: If the area to be paved is large (→ 300 m²), it might be preferable to compact the soil with medium size rollers.

i NOTE: It is recommended not to use any type of vibro-compactor plate on the EVO_2/E™ slabs, as they may become damaged.

LAYING ON GRAVEL

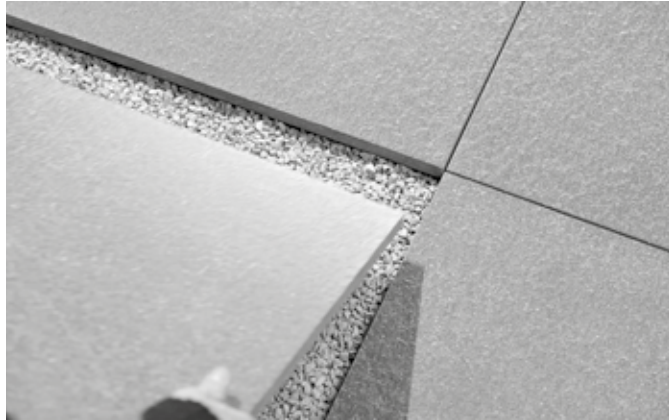

The dry laying on gravel is recommended for applications such as a garden, patio, courtyard, walkways and terraces. This allows the ground drainage unaltered through the joints between the slabs, and allows drainage of the water in the stratum.

This laying solution is also ideal for projects where permanent floor laying is not possible.

USES



Residential Areas



Footpath



Garden, courtyard or patio



Terraces

WHAT YOU NEED



Porcelain Stoneware
Mirage® Evo_2/E™



Spade



Spirit level



Vibro compactor plate



Cement



Concrete mixer



Waterproof sheath



Honeycomb mat



Gravel Ø 3/6 mm



Bar grader



Mirage® Space_G plus spacers



Mallet

LAYING IN PLACE

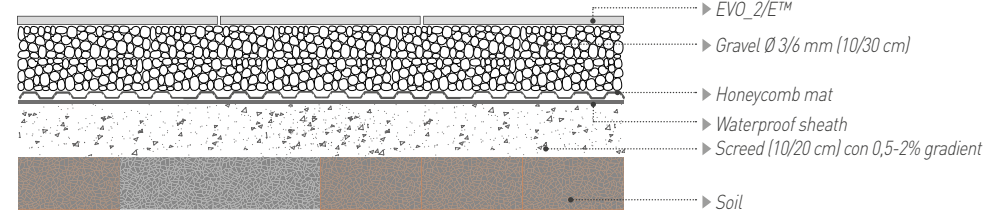

Once you have drawn up the area you need to dig out, you can mark the perimeter of the excavated area using wooden or steel marker posts connected by a string.

Allow a lateral strip of land in excess of the marked edge that can be removed during the excavation.

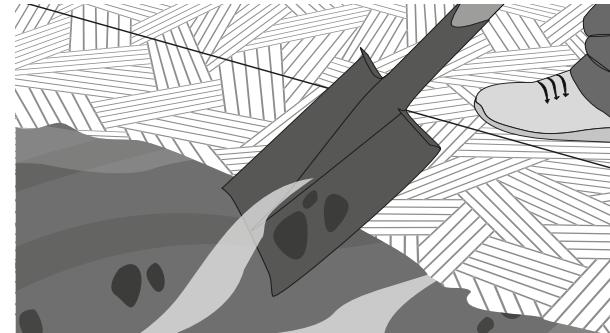

Remove the soil inside the marked area using a shovel or excavator. The depth of excavation should be decided during the planning stage and depends on various factors that the flooring fitter should assess with due care, including:

- the load on the flooring; a larger service load corresponds to a greater thickness of the layers
- the existing conditions of the soil; the undisturbed ground has a greater bearing capacity than the backfill
- drainage capacity of the soil; a greater ability to drain water corresponds a greater bearing capacity of the ground



NOTE: It is recommended to consult a technician to precisely calculate the thickness of the layers according to the intended use and stressing load.

The stratigraphies, shims and the proposed measures are only indicative of the type of application: it is recommended to refer to the specific rules of each individual country or indications of the Layers' Associations, to achieve a flooring job according to the best working standards. Mirage® also recommends carrying out a careful assessment of the sub-bed characteristics before doing any type of machining or laying.



Once the excavation is completed, use a rake or shovel to level the excavated area making sure there is at least 2% slope (to facilitate water drainage). Before proceeding with the implementation of the upper layers, compact the soil with a vibro compaction machine.

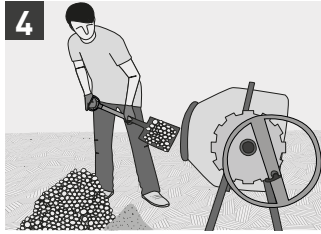

The screed, thickness 10-20 cm, must ensure a suitable support for the flooring according to the class of use. As well as having a structural purpose, the slab must also allow water to drain away at the sides; therefore the surface of the slab should have a gradient of 2-5%.

Preparation: The mixture of the screed involves the use of aggregates (gravel and sand), binder (cement), water and additives.



It is recommended to position the disposable formwork for casting the concrete slab. Then lay a welded mesh with a wire diameter of no less than 8 mm over the entire surface of the slab. Then cast the concrete as evenly as possible and finish the surface with a gradient of 2-5% using a level. Before proceeding with the subsequent steps, wait for the concrete to harden.

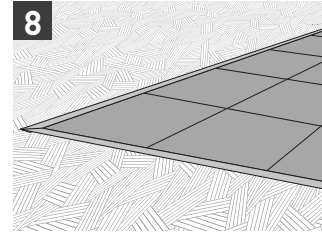

The edging stones or curb stones have the basic purpose to prevent any horizontal movements of the flooring by eliminating any instability of the paved plane. A curb must be fitted along the entire perimeter of the flooring, unless it is in direct contact with a footpath, wall or an existing edge that is sufficiently rigid. It is recommended to install the containing edges during the stage prior to laying the gravel bed on which the flooring is placed.

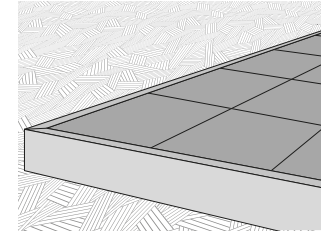

The containing edge must be fixed to the ground with a casting of concrete at the base or by mechanical anchors according to manufacturer-specific indications and according to the material of which they are made. If possible, at least half the height of the curb should be covered with soil on the external side of the flooring.



Lay a 10-30 cm thick layer of gravel, depending on the intended use, on top of the honeycomb mat. Using 3/6 mm diameter gravel will give the slab greater stability. Level the surface with two guides and a board. To confer greater stability to the layer of gravel, you can use a cement mixer to mix the gravel with 5% cement and a minimal amount of water.

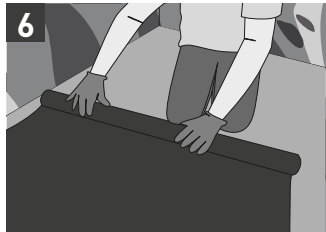

In order to avoid the absorption of water by the screed, install a waterproof sheath, making sure to cover the entire area.

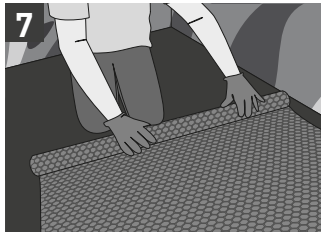

Then put the honeycomb mat into position, trimming away any excess at the sides using a cutter. The honeycomb mat serves to channel the water, improve the lateral drainage and protect the waterproofing.



Using the same method as for the foundation layer, lay gravel with a size of 0/20 mm, a thickness between 10 and 20 cm, according to the expected load. This layer also has to be compacted and levelled with a gradient of approximately 2%.

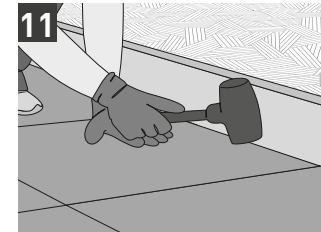

Start laying EVO_2/E™ using Mirage® Space_G type plus spaces (joint 4 mm). Use a rubber mallet to stabilise the slab on the bed of sand by delicately tapping the surface.

12
GROUTING: see information on page. 32.



NOTE: It is recommended not to use any type of vibro-compactor plate on the EVO_2/E™ slabs, as they may become damaged.

LAYING ON GRAVEL MIXED WITH CONCRETE.....



Dry laying on gravel mixed with cement is recommended for applications such as a garden, patio, courtyard, walkways and terraces. Overall, this is more stable than a dry installation but also more difficult to remove.

USES



WHAT YOU NEED



LAYING IN PLACE

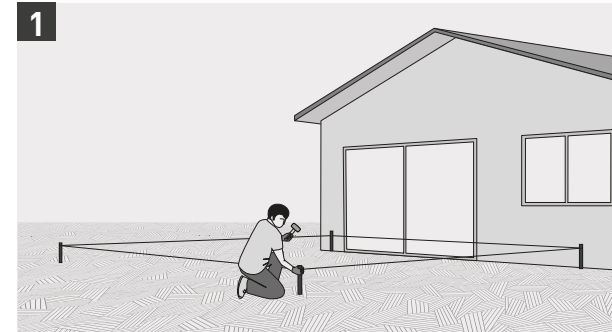
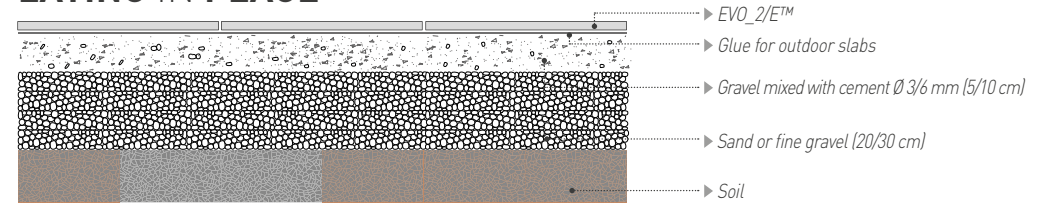

Once you have drawn up the area you need to dig out, you can mark the perimeter of the excavated area using wooden or steel marker posts connected by a string. Allow a lateral strip of land in excess of the marked edge that can be removed during the excavation.

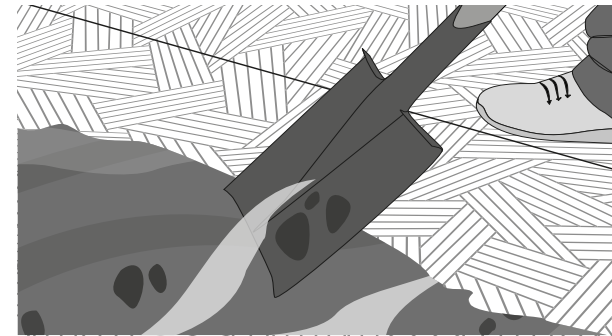

Remove the soil inside the marked area using a shovel or excavator. The depth of excavation should be decided during the planning stage and depends on various factors that the flooring fitter should assess with due care, including:

- the load on the flooring; a larger service load corresponds to a greater thickness of the layers
- the existing conditions of the soil; the undisturbed ground has a greater bearing capacity than the backfill
- drainage capacity of the soil; a greater ability to drain water corresponds to a greater bearing capacity of the ground

NOTE: It is recommended to consult a technician to precisely calculate the thickness of the layers according to the intended use and stressing load.

The stratigraphies, shims and the proposed measures are only indicative of the type of application: it is recommended to refer to the specific rules of each individual country or indications of the Layers' Associations, to achieve a flooring job according to the best working standards. Mirage® also recommends carrying out a careful assessment of the sub-bed characteristics before doing any type of machining or laying.

LAYING ON GRAVEL MIXED WITH CONCRETE



Once the excavation is completed, use a rake or shovel to level the excavated area making sure there is at least 2% slope (to facilitate water drainage). Before proceeding with the implementation of the upper layers, compact the soil with a vibro compaction machine.



After compacting the base, start to lay the foundation layer, load-bearing element of the stratigraphy, of fine gravel or sand, which should be between 20 and 30 cm thick depending on the type of load envisaged.



It is then necessary to compact the gravel layer with a compactor roller or with a vibro plate compactor, keeping the surface linear and the minimum gradient of approximately 2% with the use of a rake.

i It is possible to use geotextile as a divider between the soil and gravel layer, the thickness depending on the intended use and stressing load.

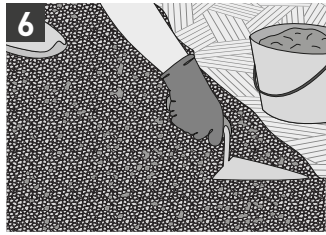

With the use of a mixer (a cement mixer is preferable), mix gravel having a 3/6 mm diameter with 5% cement and, if necessary, a minimal amount of water. When the mixture is ready, use a trowel to spread out the layer and then level it to lay the slab. If the joints between the flooring tiles is not permeable, the flooring must have a 2% gradient.

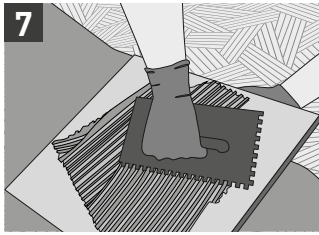

For optimum adhesion of the slab to the layer underneath and a longer working life of the finished flooring, it is recommended to use a special glue for outdoor slabs. Spread the glue on the back of the slab using a notched spatula. Make sure there is no excess adhesive at the sides of the slabs. Lay the EVO_2/E™ element on the layer of gravel and cement mix.

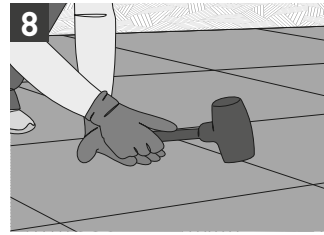

Press down gently and then tap the surface of the slab with a rubber mallet to embed it properly. Before the adhesive sets, make sure the joints are not clogged: remove any excess if necessary.

9
GROUTING: see information on page. 32.

i It is important to paste the slab when the compound gravel mixed cement is still wet so as to exploit the capacity of the cohesive cement.
NOTE: It is recommended not to use any type of vibro-compactor plate on the EVO_2/E™ slabs, as they may become damaged.



JOINTS

Joints recommended for EVO_2/E™ flooring are 4 mm; in addition to improving the aesthetics, the joint has the function of absorbing any movement of the slab, preventing breakage of the same. To create a joint of suitable width, use the spacers having a thickness of 4 mm, which are positioned respectively at the intersections between the slabs. Special spacers for the laying on gravel and sand are the Space_G type spacers supplied by Mirage®.

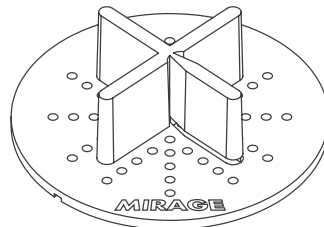
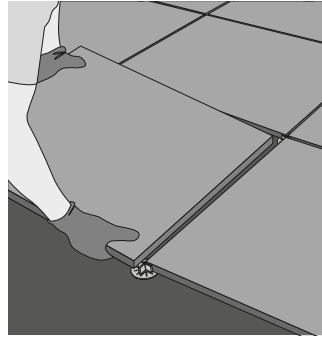

Mirage® Space_G plus spacers

There are five different types of joints, depending on the flooring methods and performance needs of the fitter:

- Empty joint
- Joint with normal sand
- Joint with polymer sand
- Joint with cement sand
- Joint with grout

EVO_2/E™ Joint type

| | LAYING IN SUPPORT WITH GRASS | LAYING ON SCREED WITH GLUE | RAISED LAYING | LAYING ON SAND | LAYING ON GRAVEL | LAYING ON GRAVEL MIXED WITH CONCRETE |
|-------------------------------|------------------------------|----------------------------|---------------|----------------|------------------|--------------------------------------|
| EMPTY GAP | • | | • | • | • | • |
| GAP FILLED WITH NORMAL SAND | | | | • | • | • |
| GAP FILLED WITH POLYMER SAND | | | | • | • | • |
| GAP FILLED WITH CEMENT SAND | | | | • | • | • |
| GAP FILLED WITH POLYMER GROUT | | • | | | | |

COMPACTION

It is necessary to compact backfill layers (such as soil, gravel or sand) in order to improve their mechanical properties; it is possible to increase the density of the material by reducing any air pockets between the aggregates and limit settling to increase its load bearing capacity.

WHAT YOU NEED

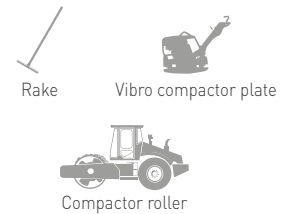

i For compaction you can use a vibratory plate compactor or a roller compactor. The thickness of material that is actually compacted depends on the weight of the equipment used. The number of repeat runs needed to achieve the optimum density depends on the vibration frequency as well as on the weight and the water content. The number of repeat runs varies from a minimum of two to three (assess on a case by case basis) depending on these parameters.

Use a rake to spread out the material for an even surface. You can use the back of the rake to level out the layer. Use the vibratory plate compactor to compact the layer according to the procedure described below:

- Start out by compacting around the perimeter, starting at the sides.
- Continue working in straight lines from the perimeter to the middle.
- Repeat once or twice using the same technique, but in the opposite direction.

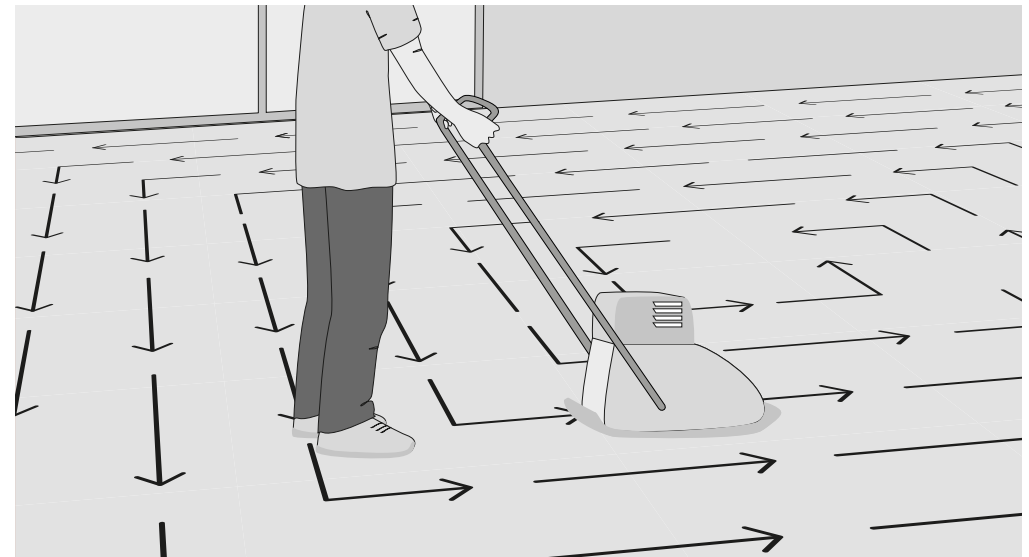

! NEVER COMPACT THE PORCELAIN STONEWARE PAVING; COMPACT ONLY THE INDICATED LAYERS. THE COMPACTION PLATE OR ROLLER COULD DAMAGE THE SURFACE OF THE SLAB, EVEN IF FITTED WITH THE APPROPRIATE RUBBER PROTECTORS.

JOINTS

EMPTY JOINT

The empty joint is such that it does not include any material in its interior between one slab and the other; for this reason it cannot absorb the relative movements between the slabs, and therefore risks movement in some cases.

It is recommended to ensure a good outflow of water in winter because the formation of ice could damage the flooring.

Weeds can grow in empty joints and insects and ants will be able to nest there.

It is definitely a type of joint that is simple to implement, but it needs routine maintenance (cleaning weeds, etc.).

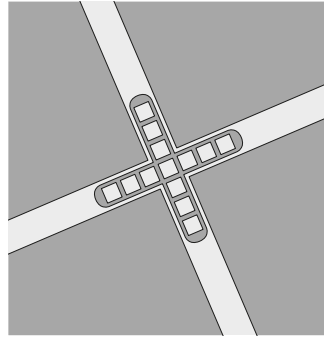

i For the laying of gravel (3-6 mm) recommend the use of spacers Space_G of Mirage® (joint 4 mm), providing more support to the plate simplifying obtaining a planar surface. The transparency of the material makes it less visible and the ability to break makes it possible to easily create the spacer T for straight course laying.



JOINT FILLED WITH STANDARD SAND

The joints are filled with dry sand having a 0-2 mm grain size. This joint has good mechanical properties, partially absorbing any relative movement between the EVO_2/E™ slabs.

Joints with standard sand do not prevent the formation of grass or plants; moreover insects and ants can nest there and may damage the flooring. Water can filter into the layers below so ice may form in certain laying systems, which could damage the flooring. Moreover, if the flooring is in an area that is very windy, on slopes or subject to heavy rain, the joints could become empty due to erosion. Grouting with standard sand requires routine maintenance to fill the joints.

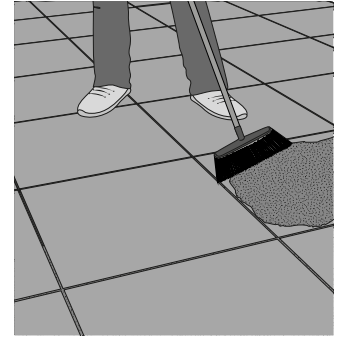

i Spread enough sand over the flooring surface and use a soft brush that will not damage the slabs; distribute the sand in the joints to fill them completely. Once the joints are full, leave excess sand on the surface.

! IT IS ADVISABLE TO FILL THE JOINTS AGAIN A FEW DAYS AFTER FINISHING THE FLOORING. THIS IS BECAUSE THE SAND INSIDE THE JOINT WILL SETTLE DOWN WHEN THE FINISHED FLOORING IS SUBJECTED TO SURFACE LOADS THAT WILL MAKE ITS VOLUME DIMINISH.

JOINTS

JOINT WITH POLYMER SAND

The polymeric sand is composed of a mixture of polymer binders and calibrated sand. Once the sand is wet, it hardens becoming very solid and locking the joints of the flooring, being equally efficient both on flat surfaces and on slopes (garage access ramps, etc.). These features make it ideal for applications in areas with excess water or steep slopes. The joints are filled with a sandy material that solidifies (draining or non-draining polymeric sand). These joints have excellent mechanical properties, absorbing the relative movements between the slabs because they are rigid at the top and flexible at the bottom. Weeds will not grow in joints filled with polymeric sand and insects and ants will not be able to make their nests there. The flooring is totally impermeable if the sand used does not allow draining and the joints remain intact, unaffected by erosion throughout time.



Spread enough sand over the flooring surface and use a soft brush that will not damage the slabs; distribute the sand in the joints to fill them completely.

It is essential to remove any excess sand on the surface once the joints have been filled (using a leaf blower if possible). When the surface is perfectly clean, spray the sand with water to start the process of polymerisation. The spray of water must be like "rainfall" from a height of 1.5 metres, without applying too much water. Spray again in the same way 5-10 minutes later.

If there are other sand particles on the surface, use a leaf blower to remove them before the flooring dries out. In dry weather, the polymerisation process will be complete in a few hours and so the flooring becomes serviceable in about 24 hours.

JOINTS FILLED WITH CEMENT SAND

This requires a sandy material inside that becomes solid (cement sand). This type of joint has excellent mechanical properties. Since cement sand is harder wearing and more resistant than polymeric sand, it is also more difficult to remove. Weeds will not grow in joints filled with cement sand and insects and ants will not make their nests there and potentially damage the flooring. This flooring is totally impermeable; once the joints have been filled they are not affected by erosion and remain intact over time.

The method of installation is the same as that of polymeric sand. It is extremely important to remove any traces of cement sand after spraying with water as it would solidify on the surface of the flooring slabs. One of the advantages of cement sand is its rapid solidification, so the flooring becomes serviceable in a few hours.



! JOINTS GREATER THAN 4 MM ARE NOT RECOMMENDED. UNLIKE POLYMERIC SAND, CEMENT SAND ALSO SOLIDIFIES IN RAINY CONDITIONS AND WITH HIGH LEVELS OF HUMIDITY, BUT NOT AT TEMPERATURES BELOW 0°C.

JOINTS WITH CEMENT GROUT

This joint has excellent mechanical properties, absorbing any relative movement between the flooring slabs and supporting the stresses induced by any differential movements. They also help to distribute the surface load, safeguarding maximum stability. Weeds will not grow in joints filled with cement grout and insects and ants will not make their nests there. The flooring is totally impermeable and the joints remain intact over time. We recommend products classified in accordance with standards EN13888 having a category not less than CG2W.

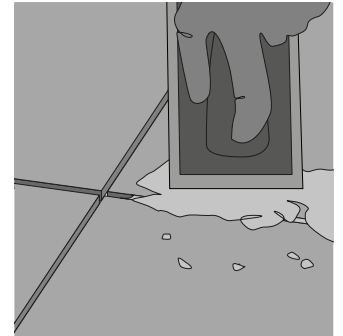

Once the glue is dry, prepare the cement grout for outdoor applications using an appropriate mixer according to the instructions and safety warnings on the product label. Check that the joints are free of glue residues and clean them if necessary, then apply the grout near the joints with a trowel. Spread the grout into the joints using a rubber spatula; make sure they are filled completely. Move the spatula diagonally across the joint to remove any excess product. Use a damp sponge to remove any residue on the surface immediately after filling the joints. The grout will be completely dry in about 24 hours; at this point, finish removing any tiling residue on the surface with a water and buffered acid solution. Finally, rinse with plenty of water.

! JOINTS GREATER THAN 4 MM ARE NOT RECOMMENDED. THE SAND DOES NOT POLYMERISE AT TEMPERATURES BELOW 0° C OR IN RAINY OR VERY DAMP CONDITIONS. IF SO, BEFORE LAYING, CONSULT THE MANUFACTURER OF SAND.

i NOTE: For laying with polymeric, cement or grout joints, the flooring is not draining; therefore it is vital to make sure the flooring has a minimum gradient of 1.5% to help water run off which will occur on the surface and not in depth.

evo_2/e™
contemporary landscape

Made in Italy

41026 PAVULLO (MO) ITALY
Via Giardini nord, 225
Tel. +39 0536 29.611
Telefax +39 0536 21.065
info@mirage.it

www.mirage.it



Mirageit

Mirage.it

MIRAGE®
Ceramics.Design.Sustainability

Mirage® Granito Ceramico SpA - Maggio 2015
È vietata la riproduzione, anche parziale, dell'opera in tutte le sue forme.
Reproduction of this printed catalogue, even partially, is prohibited.

Cod. R681

Maggio 2015